

REVISIONS				
REV.	DR	DESCRIPTION	DATE	APPRVD
A	DAK	RELEASED PER CO16629	4/3/06	TE

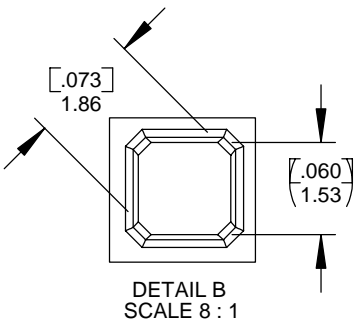
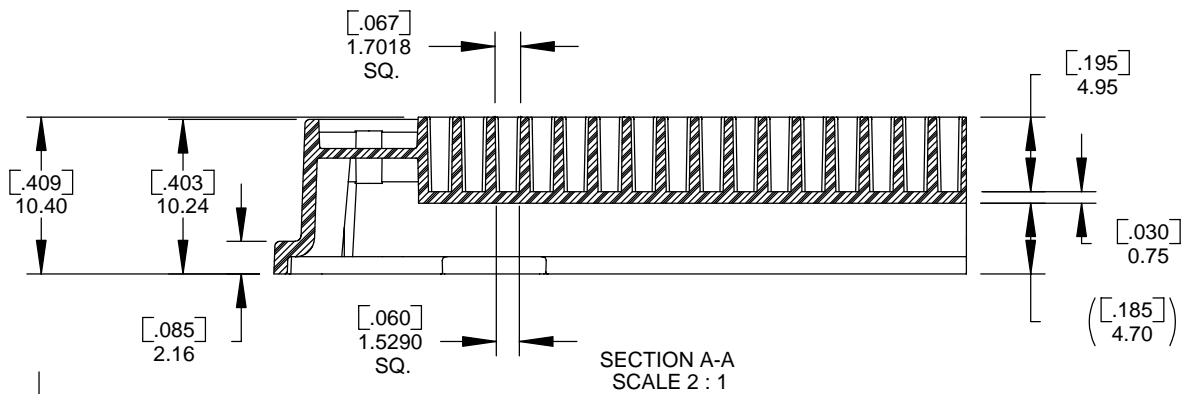
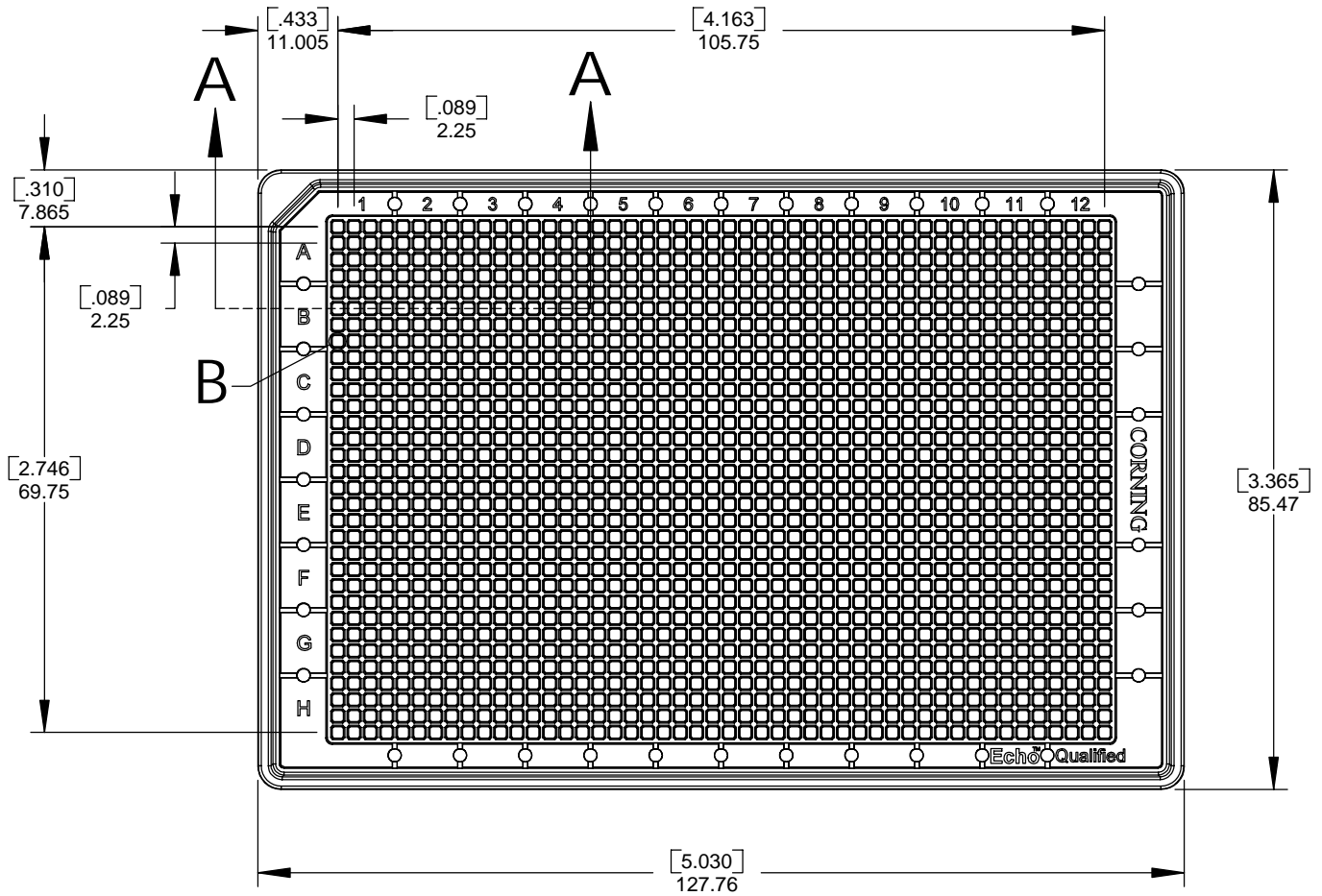

NOTES:

1. DIMENSIONS ARE [IN] mm
2. NOMINAL HEIGHT OF A STACK n NUMBER OF PLATES:
 $= 9.10n + 1.14$ MILLIMETERS
 $= .358n + .045$ INCHES

CORNING
 Life Sciences
 45 Nagog Park
 Acton, MA 01720

TOLERANCES - UNLESS SPECIFIED
 DIMENSIONS ARE NOMINAL
 FOR REFERENCE ONLY.

DRAWN KMYB DATE 05/25/05
 CHKD TE 4/3/06
 MATL SEE PRODUCT DESCRIPTION

1536 WELL PLATE,
 ECHO™ QUALIFIED

CUSTOMER SPEC.

PROD CODE 144 SHEET 1 OF 1

DWG01953

REV A