

| REVISIONS | | | | |
|-----------|-----|-----------------------|--------|--------|
| REV. | DR | DESCRIPTION | DATE | APPRVD |
| A | DAK | RELEASED PER CO#17392 | 8/3/06 | TE |

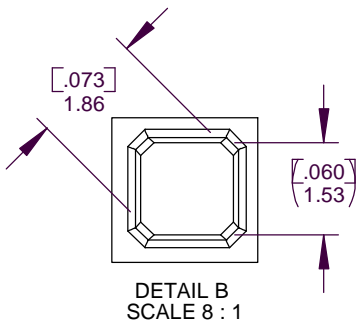
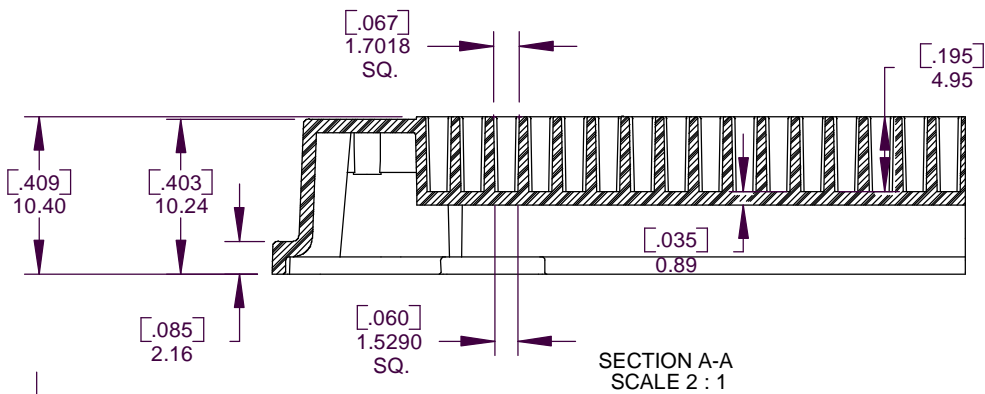
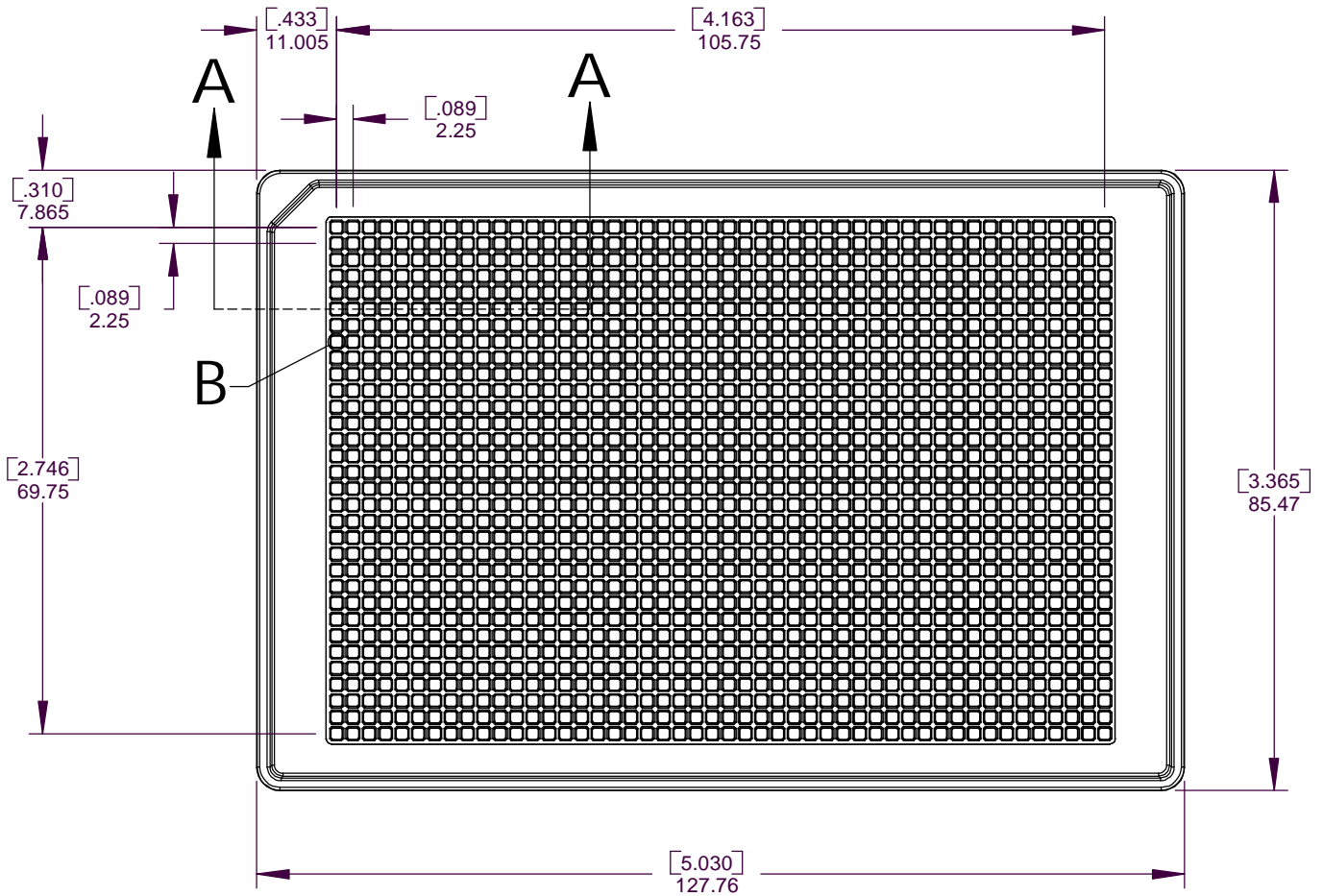

NOTES:

- DIMENSIONS ARE [IN]
mm

CORNING

Life Sciences

45 Nagog Park
Acton, MA 01720

TOLERANCES - UNLESS SPECIFIED
DIMENSIONS ARE NOMINAL
FOR REFERENCE ONLY.

CUSTOMER SPEC.

DRAWN KMYB DATE 10/13/05
CHKD TE 8/3/06
MATL SEE PRODUCT DESCRIPTION

PROD CODE 144

SHEET 1 OF 1

1536 WELL PLATE, 10 μ L
10.4mm HT, HIGH BASE,
HIGH WEB

DWG01992

REV A