

REVISIONS				
REV	DR	DESCRIPTION	DATE	APPROVED
A	DAK	RELEASED PER CO#25269	6-24-11	MA

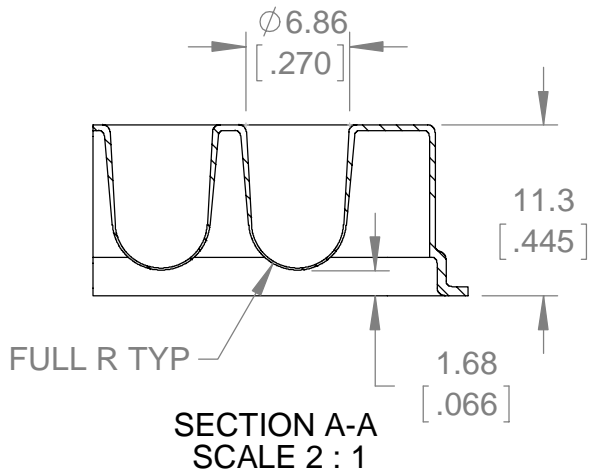

NOTES:

1. DIMENSIONS ARE IN MILLIMETERS.
2. DIMENSIONS IN PARENTHESIS ARE IN INCHES.
3. REFER TO PRODUCT DESCRIPTION FOR FURTHER PRODUCT INFORMATION.

