

REVISIONS				
REV	DR	DESCRIPTION	DATE	APPROVED
A	RET	RELEASE PER CO*07283	05/04/99	PC
B	RET	REVISED PER CO*7502	07/28/99	GP

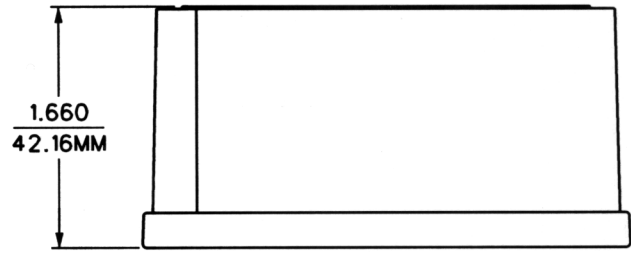
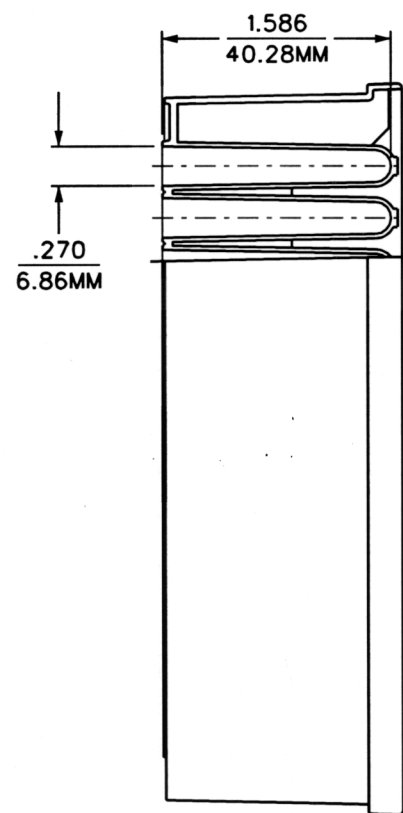
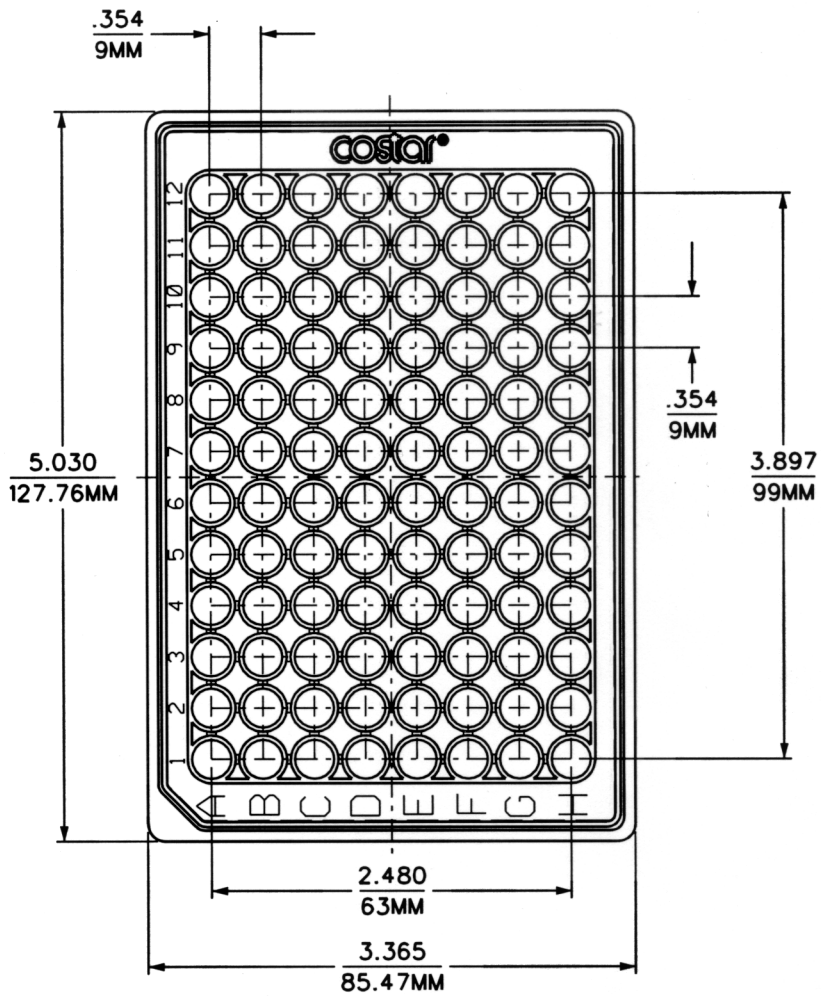

NOTE:
1. REFER TO PRODUCT DESCRIPTION FOR ADDITIONAL PRODUCT INFORMATION.

COSTAR® is a registered trademark of Corning Incorporated

PROD CODE:144

Corning Incorporated
Science Products Division
45 Nagog Park
Acton, MA 01720

Tolerances: Unless otherwise specified dimensions are nominal for reference only

Drawn MB Date 04/07/99
Chkd
Mat ISEE PROD DESCRIPTION
Customer Spec. Sht. 1 of 1

COSTAR ©
96 WELL ASSAY BLOCK
1ML. U-BOTTOM
DWG01155 Rev B