

REVISIONS				
REV	DR	DESCRIPTION	DATE	APPRVD
A	DAK	RELEASED PER CO16985	5/18/06	HA

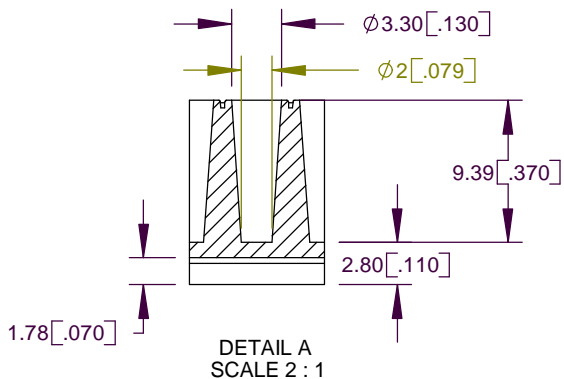
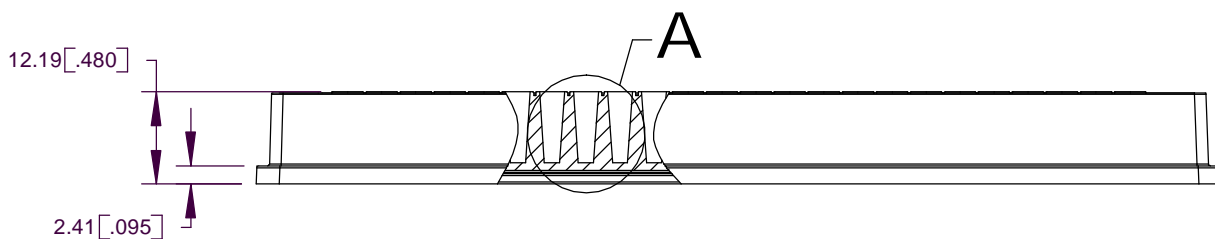
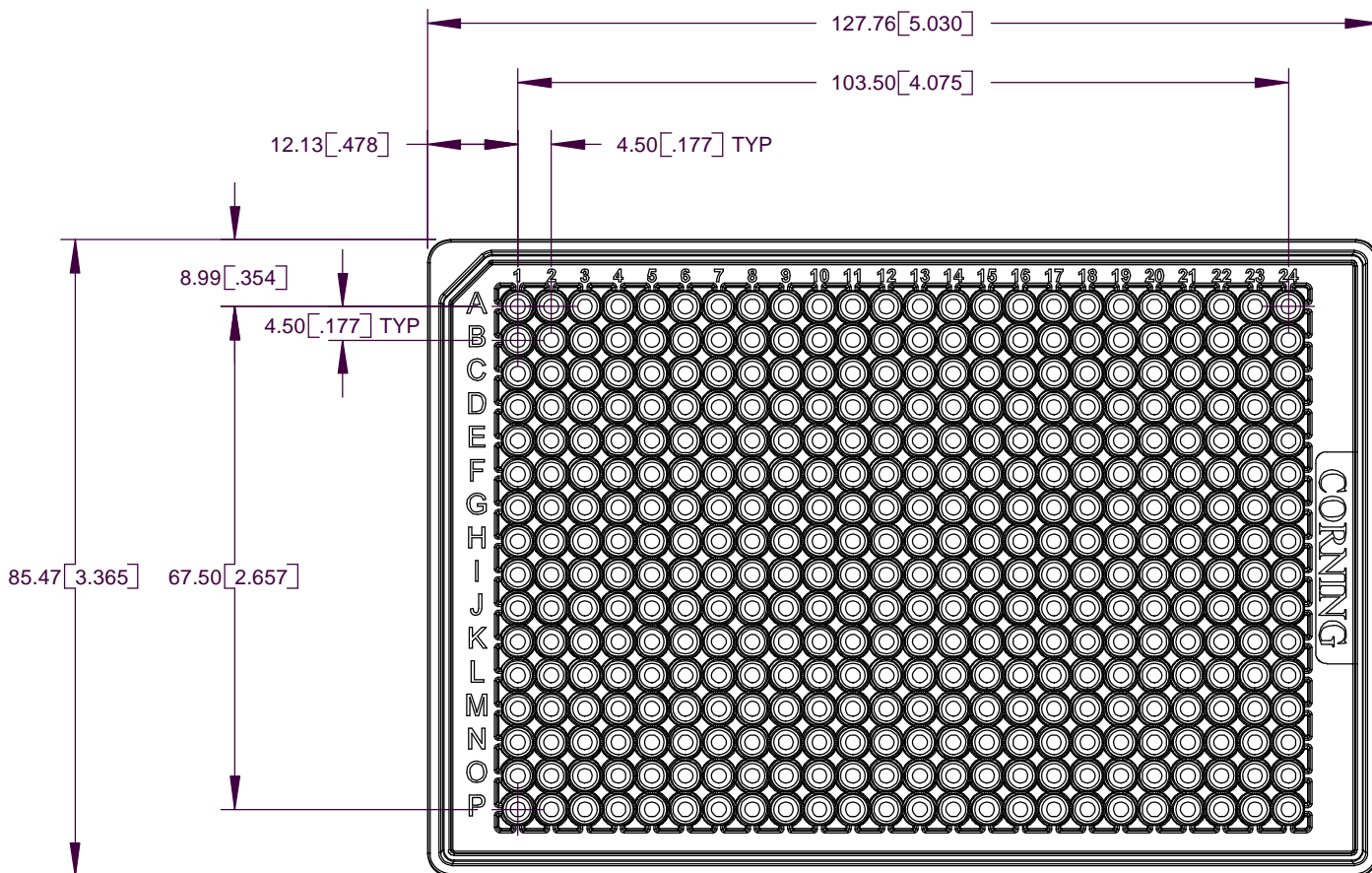

NOTES:

1. DIMENSIONS ARE MILLIMETERS, BRACKETED DIMENSIONS ARE INCHES.
2. SEE PRODUCT SPECIFICATION SHEET FOR ADDITIONAL INFORMATION.

CORNING

Life Sciences

45 Nagog Park
Acton, MA 01720

TOLERANCES - UNLESS SPECIFIED
DIMENSIONS ARE NOMINAL
FOR REFERENCE ONLY.

DRAWN KYB DATE 05/04/04
CHKD HA 5/18/06
MATL SEE PRODUCT SPECIFICATION

384 WELL LOW VOLUME,
FLAT BOTTOM PLATE

CUSTOMER SPEC.

PROD CODE 144

SHEET 1 OF 1

DWG02035

REV A