

Ordering Plug & Play™ AnyLAN™ Systems A Customer's Guide



Laser Range Finder | Photo NS99



Measuring Wheel | Photo NS101



Duct Measuring Tape | Photo NS84

Ordering a Plug & Play™ AnyLAN™ Systems distribution trunk cable can be completed in three easy steps:

1. **Design and Measure** – Design the distribution cable build plan. Measure distances between poles, handholes, pedestals or building floors to fit your specific application.

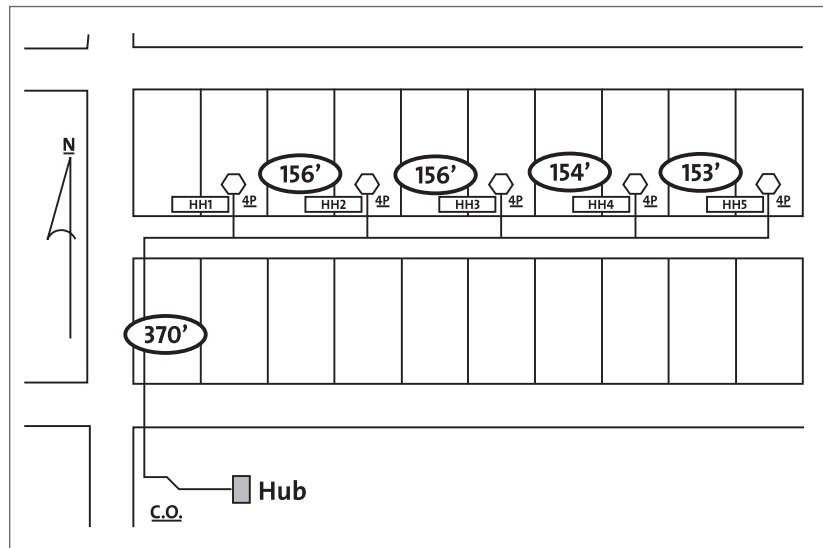

2. **Create and Submit Build Plan Online** – Contact Corning Cable Systems at 1-800-743-2671 to gain access to the Plug & Play™ AnyLAN™ Systems Online Part Number Configurator. A Systems Engineer is available to support design and configurator input.

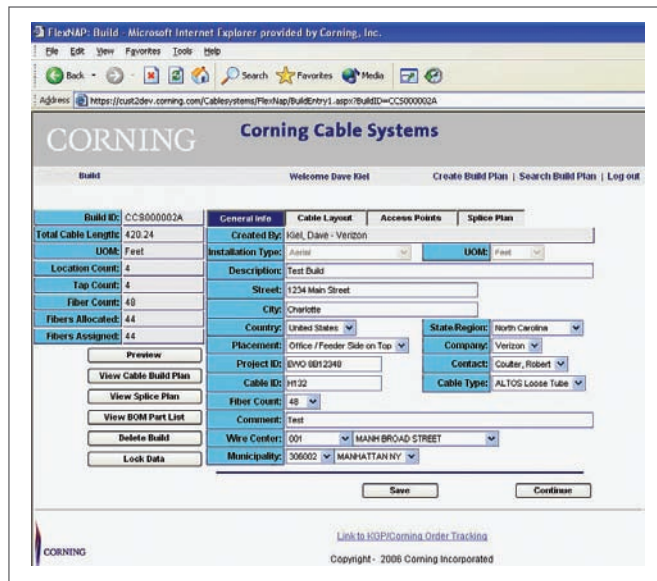

Once you have gained access and received design assistance, you upload the build plan into the configurator. The final bill of materials for the distribution trunk cable can then be downloaded for review and project documentation.

